

GPRO® P1

Gutta Percha Obturation System

Instruction for Use



Table of Contents

1. Introduction.....	3
2. Installation	5
3. Operation.....	7
4. Canal Obturation	8
5. Technical Specification.....	9
6. Signs.....	10
7. Battery Replacement.....	11
8. Safety Precautions	11
9. Maintenance	12
10. Troubleshooting.....	13
11. After-sales Service	14
12. Environment Protection	14
13. Beyes Limited Warranty Statement.....	14

Thank you for purchase Gpro P1 Gutta Percha Obturation Pen developed by Beyes Dental Canada Inc. Beyes has excellent Quality Control System. To guarantee correct and safe operation, please read this Instruction Manual carefully before use. Depending on the level of risk involved, safety requirements are classed under the following indications:



Danger: (Always refer to personal injury)



Warning: (Refer to possible damage to property)

1. Introduction

1.1 Features

- Cordless and easy to use
- Designed for both left handed or right handed individuals; both sides have display window and operation button
- Heats and cools almost instantly for optimal safety and control
- Adjustable heating range (150°C, 180°C, 200°C, 230°C)
- Auto shut off after 10 mins of idling

1.2 Intended Use

It is used to heat, cut, soften, and downpack gutta-percha to obturate root canals in endodontic treatment.

1.3 Contraindications

- Patient allergic to known natural latex and metals such as stainless steel, silver, copper
- Patient with hemophilia
- Patient or dentist with pacemaker implanted
- Patient with heart disease

1.4 Package includes

- 1) GPro P1
- 2) Charging base
- 3) Power adapter with cord
- 4) Tips

Model	Size (mm)	Taper
WP4004	40	0.04
WP4504	45	0.04
WP5506	55	0.06
WP5508	55	0.08

- 5) Heat insulation sleeve
- 6) Instruction Manual

1.5 Diagram of Components and Control Buttons

The Gpro P1 is equipped with a display screen and a control button on both the left and right sides. And the design of left and right sides are perfectly symmetrical, which enables either left-hand or right-hand operation;

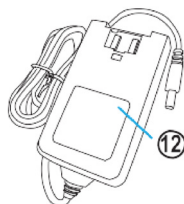
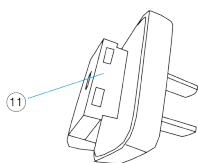
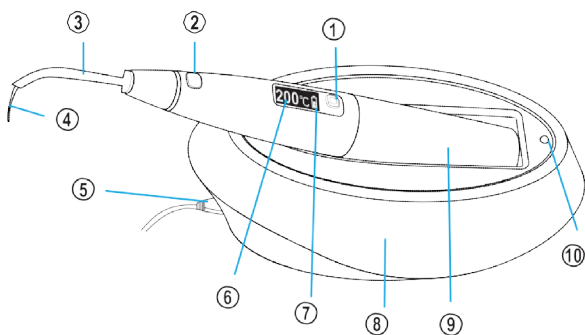

1. "ON/OFF" button
2. Heating button
3. Heat insulation sleeve
4. Tip
5. Connecting hole for power adapter
6. Temperature

7. Battery level
8. Charging base
9. Battery cartridge
10. Charging indicator
11. Power adapter plug
12. Power adapter

2. Installation

2.1 Charge device

- 1) Install the adapter plug for the power supply (Figure 2)
- 2) Plug in the power supply and connect it to the charging base (Figure 3)
- 3) Seat the device on the base for charging (Figure 4)

The display faces up and the bottom connecting pins mate the base

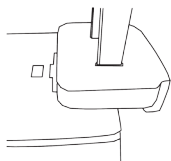

(Figure 2)

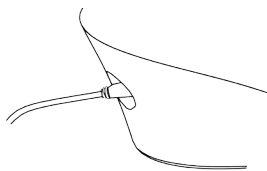

(Figure 3)

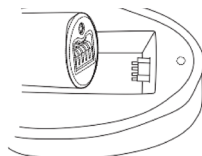

(Figure 4)

Light on the base will be yellow while battery is charging and will turn green once battery is fully charged.

If the device is off the base, light flashes between yellow and green.

Full battery charge takes around 2hr 30min

Notes: Charge battery for 3 hours before the first use.



Warning:

Do not drain battery.

Always charge to full to maintain battery life.

Recharge battery if the device has not been used for more than 1 month.

2.1 Install tip



Danger:

Do not turn on the device for tip installation
Hitting the heating button by mistake may cause scald on fingers.

Note: See Turn device on/off in Operation

Select the right tip size

Hexagonal plug on the tip allows varies tip orientation

Plug the tip into heating chamber completely

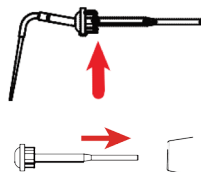

Note:

To remove the tip, hold near the turn of the tip and gently pull out



Warning:

Needle remains hot after use. Wait till display 0 °C



Warning:

Before each use, clean, disinfect and sterilize the tip
Do not autoclave this device.
Do not immerse this device into chemical disinfectant.

Turn on device



Installed properly



Bad connection

2.2 Fit insulation sleeve

Cover the thick part of the tip connecting the heat chamber

Note: Tip should not be covered

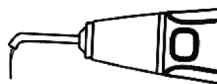

3. Operation

3.1 Turn device on/off

Press on/off button. Device turns on. Display shows current temperature of the tip and battery level.

Press and hold on/off button for 1 sec. Device turns off. Display turns off.

Note: Device will automatically shut down after 10 mins of idling

3.2 Change left/right handed

Turn device off

Press and hold on/off button. Device turns on and display shows previous direction and then toggle another direction

3.3 Select Temperature

Press and release on/off button to select the temperature setting.

Temperature setting cycles as shown below.

150°C  **180°C**  **200°C**  **230°C** 

Note:

The display shows 0°C when no button is pressed

If the tip heats up or cools down, the display shows the temperature of the tip

When selecting temperature, display momentary shows the setting and then changes to the temperature of the tip or 0°C.

3.4 Heat up the tip

Press and hold the heating button

Beep alert when tip is heating up

Display shows the tip temperature

Release button

Beep stop and display show tip temperature cooling down and back to 0°C

Note:

Pressing heating button for more than 10 sec

Tip stops heating

Device stop beeping

Display turns back to 0°C

4. Canal Obturation

- 1) Select a tip for operation
Install tip (see installation)
- 2) Shape the root canal with endo files and determine the working length. Select a master cone that closely matches the apical size.
- 3) Turn on the GPro P1 device and select the temperature (see operation)
- 4) Lightly press the heating button to heat up the tip
- 5) Insert GPro P1 tip into the root canal to the point 4-7 mm short of the working length. Move and set the endo stop accordingly.
- 6) Insert the selected master Gutta Percha cone that is coated with sealer.
- 7) Insert GPro P1 tip in the orifice of the canal to soften and pressurize the gutta-percha continuously and in stable motion.



Danger:

Do not turn on the device for tip installation
Hitting the heating button by mistake may cause scald on fingers.



Warning:

Continuous heating gutta-percha exceeding 4s is not recommended; there would be risk of scalding.

Note:

Clean, disinfect, and sterilize the tip after each patient use (see maintenance)

5. Technical Specification

5.1 Product specifications

Sizes	GPro P1 Gutta Percha Obturation Pen	23.8mm×158.3mm×23.8mm
	Charging base	75.5mm×149.7mm×62.6mm
Weight	GPro P1 Gutta Percha Obturation Pen	80g
	Charging base	207g
	Power adapter	167g

5.2 Technical parameters

Classification	Class II (AC/DC power adapter)	
Optional preset temperatures	150°C-180°C-200°C-230°C	
Time consumption for charging	About 2.5h (First charging needs 3 h)	
Power supply	Input	AC100V-240V 50/60Hz 800mA
	Output	DC15V/1.6A
Battery capacity	Chargeable battery	2000mAh

5.3 Environmental parameters



















	Working	Storage
Temperature	+5°C~+40°C	-20°C~ +55°C
Humidity	30%~75%	10% ~ 93%
Air pressure	70kPa~106kPa	70kPa ~ 106kPa



Warning:

Do not transport and store this device with hazardous articles such as combustible poisonous, caustic, or explosive.

6. Signs

	Product serial number		Follow Instructions for Use
	Manufacturer		Date of manufacture
	Type B applied part		Class II equipment
	Power switch		Ordinary equipment
	Used indoor only		Device complies with WEEE directive
	Can be autoclaved		Keep dry
	Handle with care		Recovery
	Attention! Please refer to the accompanying documents.		
	Humidity limit for storage: 10% ~ 93%		
	Atmospheric pressure for storage: 70kPa ~ 106kPa		
	Temperature limit for storage: -20°C ~ +55°C		

7. Battery Replacement

Note:

Do not unscrew the bottom screw

Hold device facing bottom

Turn battery case counterclockwise

Push battery out from bottom

Replace new battery

Battery should fit the opening at the bottom

Turn battery case clockwise to close the device

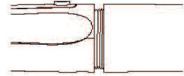

8. Safety Precautions

- 1) Do not polish the tip.
 - 2) Do not knock or scratch the GPro P1 Gutta Percha Obturation Pen
 - 3) Do not place the GPro P1 Gutta Percha Obturation Pen near an electronic device, phone, radio or HD/satellite TV as these may affect the temperature control of the GPro P1 Gutta Percha Obturation Pen.
 - 4) Keep the heating pressurizer, tip, etc. under heating state away from inflammable and explosive materials.
 - 5) Please keep the device clean before and after operation. Before each use, please disinfect tip and its accessories.
 - 6) Users should be equipped with adequate protection such as goggles, mask, etc. to prevent cross-infection.
 - 7) The product should be in strict accordance with relevant operation specifications of medical authority and relative regulations. The product can only be operated by trained doctors or technicians.
 - 8) Do not install, remove, or replace the tip under heating state. Please power off before replace the tip.
 - 9) The tip must be correctly installed to prevent it from falling off.
 - 10) When the working tip is bent or worn, it will cause uneven heating. The operator should replace the tip in time according to the clinical conditions;
 - 11) After operation, please turn off the power immediately.
- Woodpecker is specialized in producing medical instrument. We are only responsible for the safety on the following conditions:
- a) The maintenance, repair, and modification are made by the manufacturer or the authorized dealers.
 - b) The charged components are original of "Beyes Dental Canada Inc." and operated according to instruction manual.

9. Maintenance

9.1 Cleaning, disinfection and sterilization

- 1) The tip can be cleaned with clean water as well as can be cleaned in an ultrasonic cleaner.
- 2) After each use, please sterilize the tip under high temperature and high pressure (134°C, 0.22MPa) for at least 4 minutes.
- 3) If the other accessories need to be cleaned or disinfected, please use gauze to pick up a small amount of water or disinfectant to wipe the surface. Do not soak.
- 4) Do not use volatile and diffluent solvents for cleaning, which will damage the surface of the device or cause the markings on the machine to fade.

8.2 Daily maintenance

- 1) When the device is not used, please turn off the power and unplug the power supply plug.
- 2) If the GPro P1 Gutta Percha Obturation Pen is in a low battery state for a long time, the service life of battery will be shortened. Please charge it in time if the battery level is low.
- 3) When the device is not used, please charge it for 1 hour once a month.

8.3 Repair of device

This product does not contain self-repairing spare parts. Repair should be carried out by a designated professional or special repair shop.

10. Troubleshooting

Fault	Cause	Solution
No indications, no response	<ol style="list-style-type: none"> 1. Inadequate battery power 2. Battery is damaged. 3. The charging interface is short-circuited, causing the lithium battery to enter a protection state; 4. GPro P1 Gutta Percha Obturation Pen is damaged. 	<ol style="list-style-type: none"> 1. Connect to power supply to charge. / Replace the battery. 2. Replace the battery. 3. Remove the substance that causes the short circuit, put the device into the charging base to charge, and then the device will return to normal; 4. Contact local distributor or manufacturer.
Automatic shutdown	If there is no operation for 10 minutes, the device will automatic powers off.	Reboot
Tip works abnormally	<ol style="list-style-type: none"> 1. The tip is damaged. 2. Malfunction of main unit 	<ol style="list-style-type: none"> 1. Replace the tip 2. Send it to the repair center.
The pushing ram cannot be pulled out	The portion of the pushing ram that enters the interior of the heating chamber is fixed by the cooling of the gutta-percha.	<ol style="list-style-type: none"> 1. Power on and set the temperature to 200 °C. After the temperature reaches the set value, pull out the pushing ram back; 2. Contact your local dealer or our company.
Charging failure after connecting to power supply.	<ol style="list-style-type: none"> 1. The power supply is not correctly connected; 2. The power supply is damaged, or the specification doesn't match. 3. There are impurities on the contact thimble of charging base. 	<ol style="list-style-type: none"> 1. Unplug and reconnect. 2. Replace the battery. 3. Wipe the thimble with alcohol, dry it, and reconnect.
The service time after each charging is shortened	The battery ages and the battery capacity become smaller.	Contact local distributor or manufacturer to buy new batteries for replacement.
OPEN code appears on display screen	<ol style="list-style-type: none"> 1. The tip is damaged. 2. The tip is not installed. 3. The tip is not well installed. 	<ol style="list-style-type: none"> 1. Replace the tip. 2. Install the tip. 3. Unplug the tip, and reconnect.

If the problem still cannot be solved, please contact your local dealer or Beyes Dental Canada Inc.

11. After-sales Service

Starting from the date of sales, if the device does not function up to standard due to manufacturer defect, our company will be responsible for the repair of device during its warranty period. Please refer to the warranty card for warranty period and scope.

12. Environment Protection

The device does not contain any harmful substances. It may be handled or disposed in accordance with the relevant local regulations.

Note:

- 1) Without Beyes agreement and authorization, private modification of device may result in the electromagnetic compatibility problem of that device or other devices.
- 2) The design and test of Melting and Filling Gun complies with the related operation regulations of electromagnetic compatibility.

13. Beyes Limited Warranty Statement

13.1 SCOPE OF WARRANTY

BEYES Dental Canada Inc. warrants to the original retail purchaser that it will be at BEYES option to repair or replace components of the dental products manufactured by BEYES (except for components not warranted under 'Exclusions') that are defective in material or workmanship under normal use and service. BEYES' obligation under this limited warranty is limited to the repair or replacement of the applicable components. This limited warranty shall only apply to defects that are reported to BEYES within the applicable warranty period and which, upon examination by Beyes, prove to be defective. This warranty extends only to the first retail purchaser of a product and is not transferable or assignable. Replacement components or products may be used and/or refurbished components or products, provided they are of like quality and specifications as new components or products.

13.2 APPLICABLE WARRANTY PERIOD

The applicable warranty period, measured from the date of invoice to the original user, shall be as follows Gpro P1 are warranted for a period of 12 months

13.3 EXCLUSIONS

This limited warranty does not cover and BEYES shall not be liable for the following;

- 1) Defects, damage or other conditions caused, in whole or in part, by misuse, abuse, negligence, alteration, accident, freight damage, negligent storage, tampering or failure to seek and obtain repair or replacement in a timely manner;
- 2) Products which are not installed, used, and properly cleaned and maintained as required or recommended in the BEYES 'Installation' and/or 'Installation/Operation Manual' for the applicable product, including the specified structural and operational environment conditions and electrical power requirements;
- 3) Products considered to be of a consumable or sterile nature;
- 4) Accessories or parts not manufactured by BEYES;
- 5) Charges by anyone for adjustments, repairs, replacement parts, installation or other work performed upon or in connection with such products which are not expressly authorized in writing in advance by BEYES;
- 6) Costs and expenses of routine maintenance and cleaning;
- 7) Representations and warranties made by any person or entity other than BEYES;
- 8) Matching of color, grain or texture except to commercially acceptable standards;

- 9) Changes in color caused by natural or artificial light;
- 10) Custom manufactured products;
- 11) Alterations or modifications to the product by any person or entity other than BEYES;
- 12) Products that would otherwise be covered under Sections 1 and 2 of this limited warranty, but are acquired: (i) from a person or entity that is not BEYES or one of its authorized dealers; or (ii) from a BEYES dealer that is not authorized to sell the product at issue in the geographic territory where the purchaser is located, or is not authorized to sell the product at issue within the medical, animal health or dental market, as the case may be, in which purchaser intends to use the product.

13.4 EXCLUSIVE REMEDY; CONSEQUENTIAL DAMAGES DISCLAIMER

Beyes' obligation under this limited warranty is the repair or replacement of defective parts. Beyes shall not be liable for and hereby disclaims any direct, special, indirect, incidental, exemplary or consequential damages or delays, including, but not limited to, damages for loss of profits or income, loss of use, downtime, cover and employee or independent contractor wages, payments and benefits.

13.5 WARRANTY DISCLAIMER

This limited warranty is beyes only warranty and is in lieu of all other warranties, express or implied. Beyes makes no implied warranties of any kind including any implied warranties of merchantability or fitness for a particular purpose. This warranty is limited to the repair or replacement of defective parts.

13.6 STATUE OF LIMITATIONS

No actions may be brought against beyes for breach of this limited warranty, or implied warranty, if any, or for any other claims arising out of or relating to the products, more than ninety (90) days following expiration of the limited warranty period.



Federal law restricts this device to sale by or on the order of a dentist, physician, or any other practitioner licensed by the law of the states in which he or she practices to use or order the use of this device.

Beyes Dental Canada Inc.
23-595 Middlefield Road
Toronto, Ontario, M1V 3S2
Canada
Tel: 1-855-603-1888
Fax: 1-855-720-1228
Email: info@beyes.ca
Website: www.beyes.ca



Lotus NL B.V.
Koningin Julianaplein 10, Ie Verd,
2595AA, The Hague,
Netherlands
Tel: +31645171879 (English)
+31626669008 (Dutch)
Email: info@beyes.ca
Website: www.beyes.ca



Printed in Canada
ENI036
Rev. 1/12.03.21